

# MIL43

\_REV1.1



CEADESIGN STUDIO



## MIL43/MILO360

AISI 316L STAINLESS STEEL

Gruppo 2 miscelatori a parete per vasca/doccia con doccia

Wall mounted 2 mixers set for bathtub/shower with hand shower



PRODOTTI CORRELATI / RELATED PRODUCTS

FRE74 - FRE202 - MIL91



Prodotto che necessita di parte incasso  
Product that needs built-in part



Staffa ausiliaria per cartongesso / fibrogesso  
Auxiliary bracket for plasterboard / fiber-board structures

MANUTENZIONE / MAINTENANCE

NON UTILIZZARE DO NOT USE		acido clorico e muriatico chloric and muriatic acid
		acido fluoridrico hydrofluoric acid
		ipoclorito di sodio chlorine bleach
UTILIZZARE TO USE		detergente a pH neutro neutral pH detergent

Questi disegni sono proprietà di CEADESIGN SRL s.u. pertanto non potranno essere utilizzati e/o comunicati a terzi, anche in forma parziale, senza preventiva autorizzazione. CEADESIGN SRL s.u. si riserva il diritto di apportare modifiche ai disegni al fine di migliorare il prodotto.

CEADESIGN SRL s.u. has the property rights on these drawings, therefore they cannot be used and/or transferred to third party, even in partial form, without any prior authorization. Furthermore CEADESIGN SRL s.u. reserves the right to apply any change to these drawings in order to upgrade the product.

# CEA

ceadesign.it

H (mm)

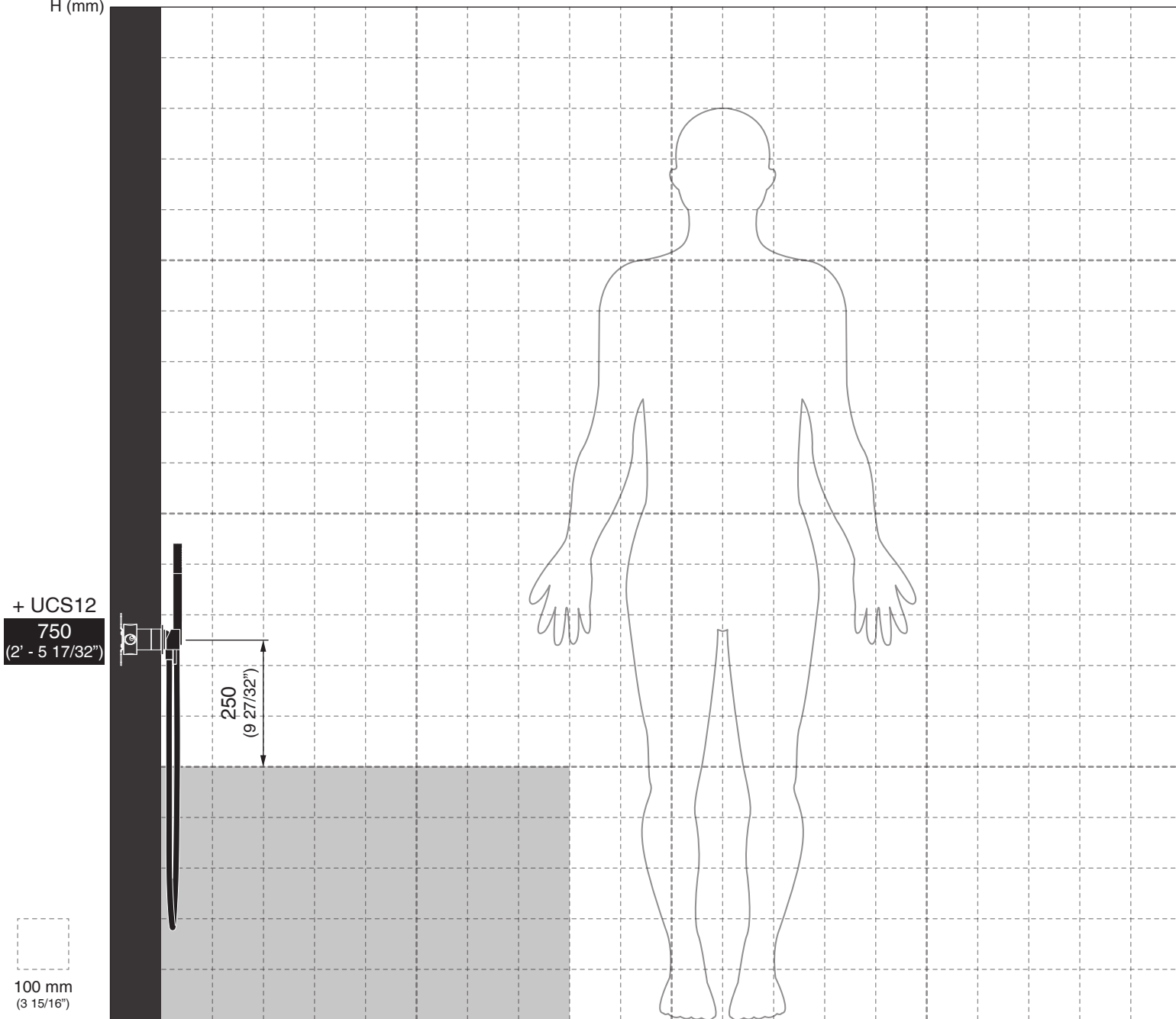

+ UCS12  
750  
(2' - 5 17/32")

250  
(9 27/32")

100 mm  
(3 15/16")

0

L (mm)

MIL43 \_REV1.1



#### AVVERTENZE DI INSTALLAZIONE

**L'altezza ottimale di installazione del prodotto è di 250 mm (9 27/32") sopra il bordo vasca.**

La rappresentazione ha valore puramente indicativo.

#### INSTALLATION WARNINGS

**The optimal installation height of the product is 250 mm (9 27/32") above the bath tub rim.**

The representation is purely indicative.

#### INSTALLATIONS WARNUNG

**Die optimale Einbauhöhe des Produkts beträgt 250 mm (9 27/32") über dem Wannenrand.**

Die Zeichnung ist rein indikativ.

#### ADVERTENCIAS DE INSTALACIÓN

**La altura de instalación ideal del producto es de 250 mm (9 27/32") sobre del borde de la bañera.**

La representación es indicativa.

#### AVERTISSEMENTS D'INSTALLATION

**La hauteur optimale d'installation du produit est de 250 mm (9 27/32") au-dessus du bord de la baignoire.**

La représentation est purement indicative.

Le portate indicate sono alla pressione consigliata di 3 bar

*The indicated flow rates are at the recommended pressure of 3 bar*

#### PORTATE / FLOW RATE

Doccetta acciaio inox / *Stainless steel hand shower*

15,4 l/min / 4.1 gpm

Doccetta gomma silconica / *Silicone rubber hand shower*

11,5 l/min / 3 gpm

Uscita remota / *Remote outlet*

23,1 l/min / 6.1 gpm

CEA

ceadesign.it

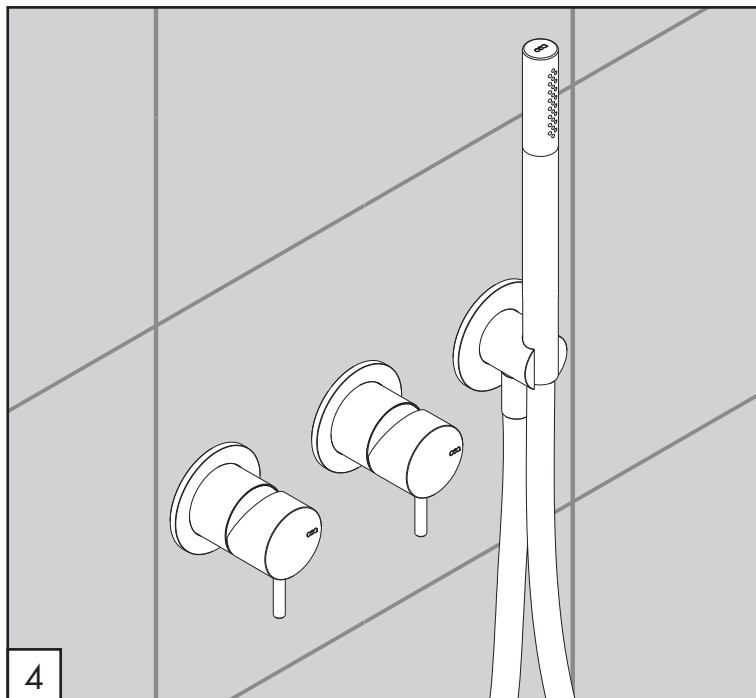
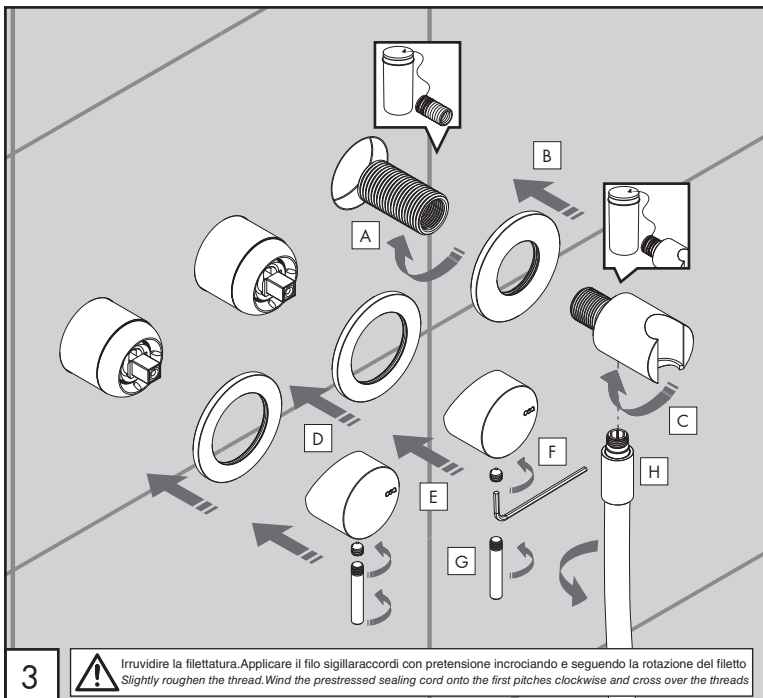
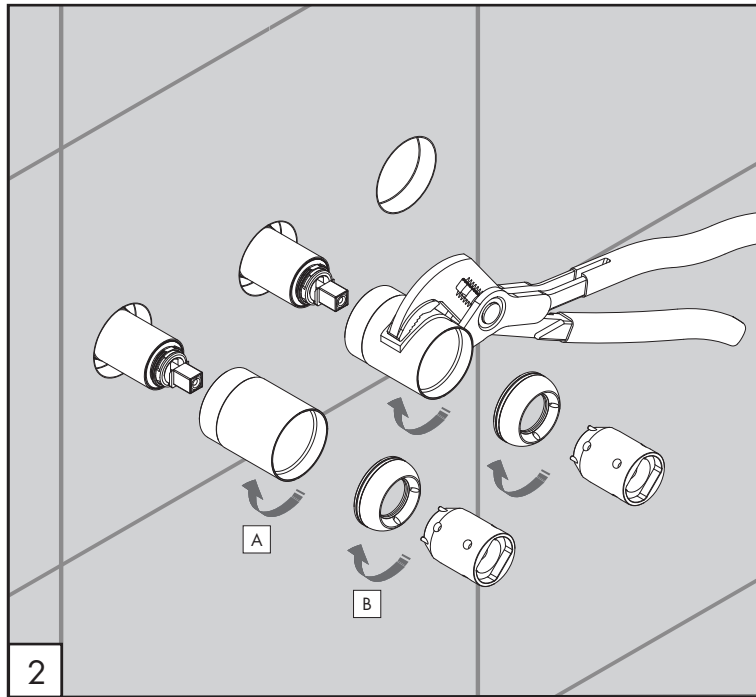
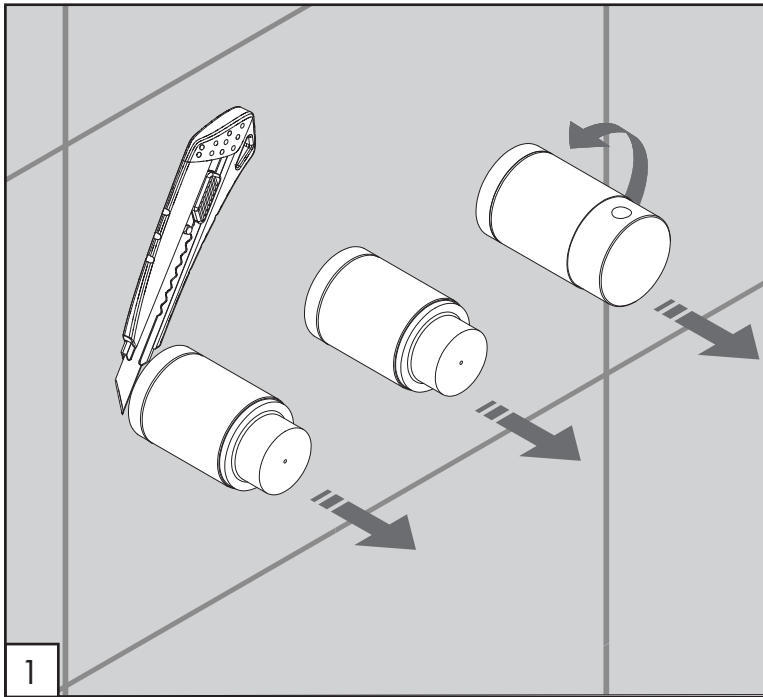

## AVVERTENZE TECNICHE

Risciacquare bene le tubazioni prima del montaggio ed evitare sbalzi di pressione fra i raccordi d'acqua fredda e d'acqua calda. In caso di pressioni statiche superiori a 5 bar si raccomanda l'installazione di un riduttore di pressione per evitare danni alla cartuccia.

## TECHNICAL WARNINGS

The pipes have to be rinsed thoroughly before installation. Avoid pressure differences between hot and cold water supply. Use of a pressure reducer when static pressure is higher than 5 bar to avoid damage of the cartridge.

## TECHNISCHE WARNUNG

Spülen Sie die Leitungen vor dem Einbau und verhindern Sie Wasserdruckwechsel zwischen kalt und warm Wasserverbindungen. Wenn Wasserdruck größer als 5 bar ist, bitte reduzieren Sie den Systemdruck, um Beschädigung der Kartusche zu verhindern.

## ADVERTENCIA TÉCNICA

Los tubos tienen que ser enjuagados a fondo antes de la instalación. Evitar grandes diferencias de presión entre las conexiones de agua caliente y fría. En caso de presión estática mayor de 5 bar, se recomienda el uso de un adaptador de presión para evitar daños en el cartucho.

## ADVERTISSEMENTS TECHNIQUES

Rincer les tuyaux avant l'installation. Eviter des grandes différences de pression entre l'eau froide et chaude. En cas de pressions statique de plus de 5 bar, nous vous recommandons d'installer un réducteur de pression pour éviter des dommages à la cartouche.

## TEMPERATURA DI ESERCIZIO / WORKING TEMPERATURE

max. 60 °C  
 max. 140 °F

3

Irruvidire la filettatura. Applicare il filo sigillaraccordi con pretensione incrociando e seguendo la rotazione del filetto  
*Slightly roughen the thread. Wind the prestressed sealing cord onto the first pitches clockwise and cross over the threads*

4



## RICAMBI / SPARE PARTS

RICR031	Rosetta / Rosette
RICT004	Raccordo / Fitting
RICU002	Supporto doccia / Hand shower holder

## ROSETTA SU RICHIESTA / ROSETTE ON DEMAND

RICR117	Rosetta Ø esterno 70 mm Rosette external Ø 70 mm
---------	---

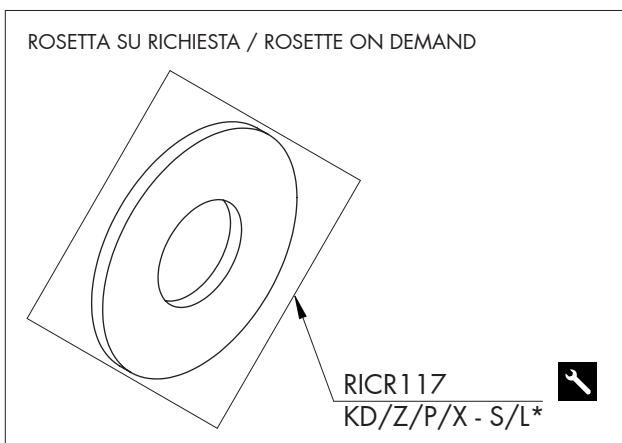
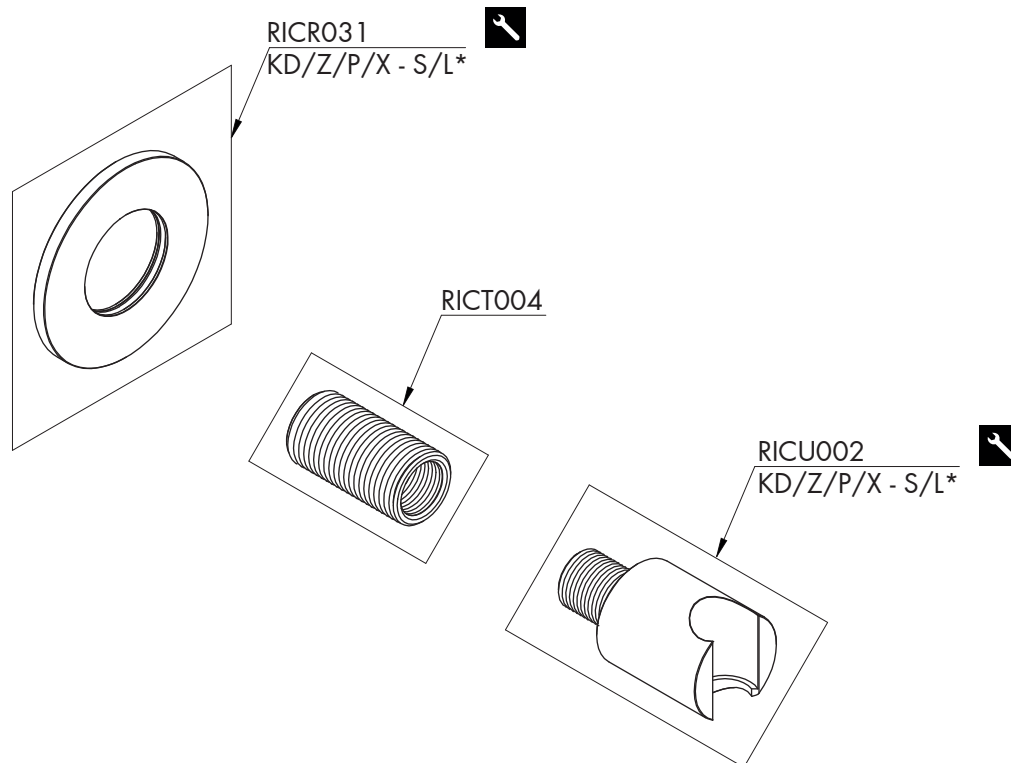

## LEGENDA / LEGEND

### ICONE / ICONS

 Utensile incluso nel ricambio  
Tool included in spare part

### FINITURE / FINISHES

\*S finitura satinata / *satin finish*  
L finitura lucidata / *polished finish*

### FINITURE SPECIALI / SPECIAL FINISHES

KD black diamond  
Z bronzo / *bronze*  
P rame / *copper*  
X light gold

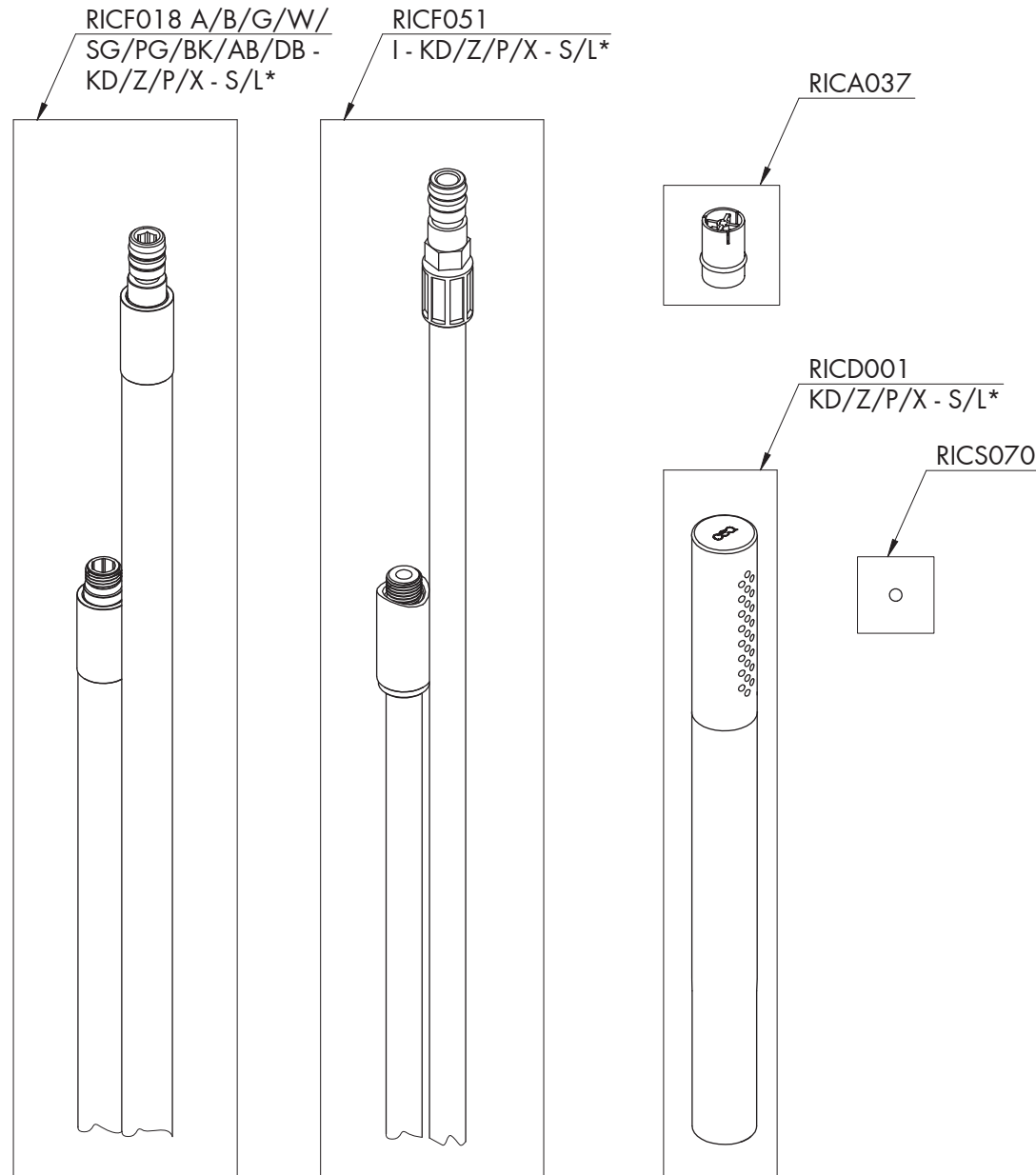

## RICAMBI / SPARE PARTS

RICA037	Valvola di non ritorno / <i>Check valve</i>
RICD001	Doccetta / <i>Hand shower</i>
RICF018	Flessibile / <i>Hose</i>
RICF051	Flessibile / <i>Hose</i>
RICS070	Sfera in acciaio inox Ø 3,5 mm <i>Stainless steel ball Ø 3,5 mm</i>

## LEGENDA / LEGEND

### ICONE / ICONS

 Utensile incluso nel ricambio  
*Tool included in spare part*

### FINITURE / FINISHES

\*S finitura satinata / *satin finish*  
L finitura lucidata / *polished finish*

### FINITURE SPECIALI / SPECIAL FINISHES

KD black diamond  
Z bronzo / *bronze*  
P rame / *copper*  
X light gold

### COLORI FLESSIBILE / HOSE COLOURS

A	verde acqua / <i>aqua green</i>	RAL 6027
B	blu cobalto / <i>cobalt blue</i>	RAL 5013
G	grigio antracite / <i>anthracite grey</i>	RAL 7043
W	bianco / <i>white</i>	RAL 9016
SG	grigio seta / <i>silk grey</i>	RAL 7044
PG	verde petrolio / <i>petroleum green</i>	RAL 5020
BK	nero / <i>black</i>	RAL 9004
AB	blu avio / <i>air force blue</i>	RAL 5014
DB	grigio quarzo / <i>quartz grey</i>	RAL 7006
I	acciaio inox / <i>stainless steel</i>	