

INC18 _REV10

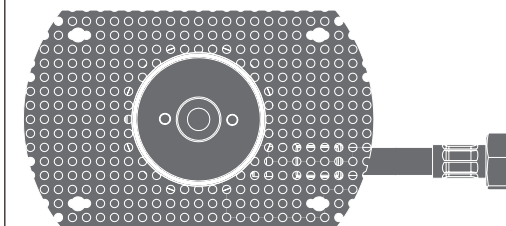

CEADESIGN STUDIO

AISI 304 STAINLESS STEEL

Corpo incasso obbligatorio per soffioni

Mandatory built-in part for shower heads

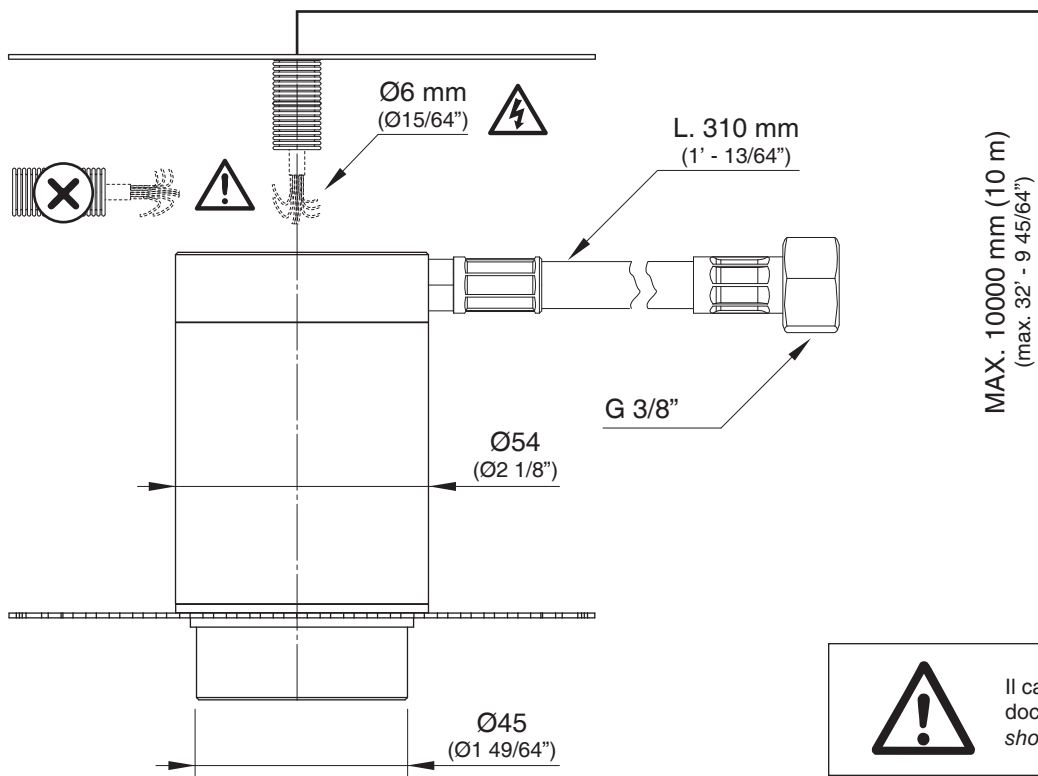

LED CONTROL UNIT
(ART. CODE ELC01)

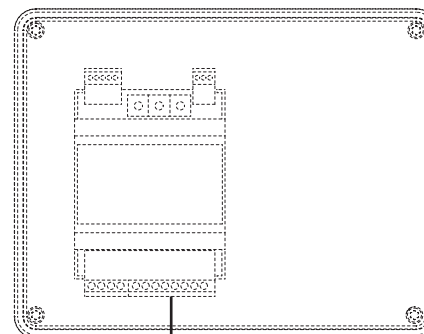

MAX. 10000 mm (10 m)
(max. 32' - 9 45/64 inches)



Il cavo elettrico Ø6 mm è compreso con il soffione doccia / The electrical cable Ø6 mm is included with shower head

PRODOTTI CORRELATI / RELATED PRODUCTS

BOT01 - ELC01 - FRE160 - FRE162 - FRE164 - FRE190

Questi disegni sono proprietà di CEADESIGN SRL s.u. pertanto non potranno essere utilizzati e/o comunicati a terzi, anche in forma parziale, senza preventiva autorizzazione. CEADESIGN SRL s.u. si riserva il diritto di apportare modifiche ai disegni al fine di migliorare il prodotto.

CEADESIGN SRL s.u. has the property rights on these drawings, therefore they cannot be used and/or transferred to third party, even in partial form, without any prior authorization. Furthermore CEADESIGN SRL s.u. reserves the right to apply any change to these drawings in order to upgrade the product.

CEA

ceadesign.it

IT

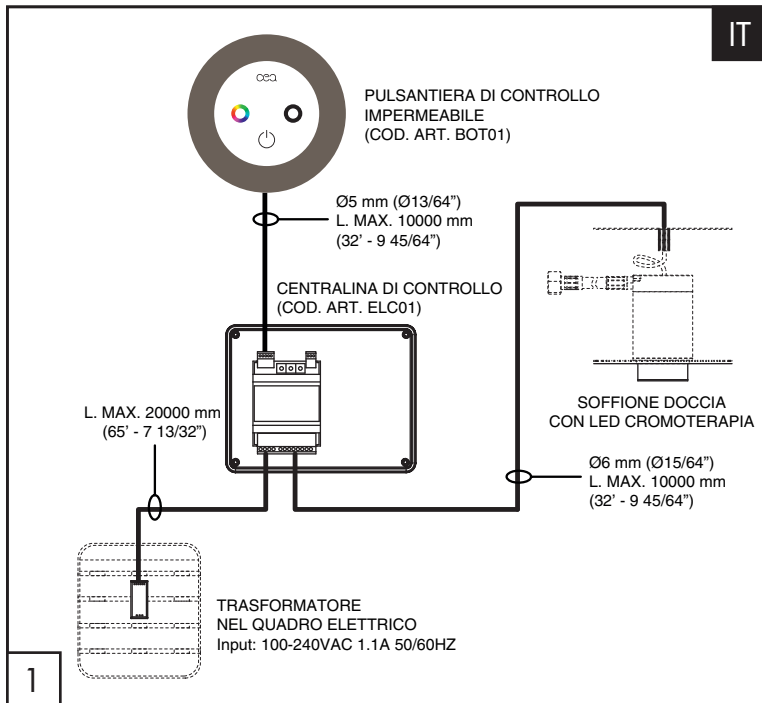

EN

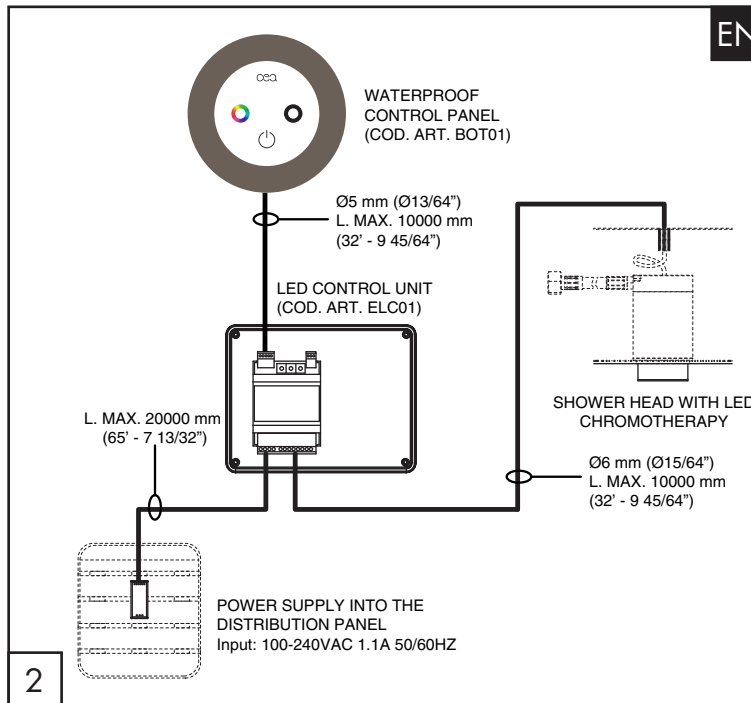

INC18_REV10

AVVERTENZE TECNICHE

Risciacquare bene le tubazioni prima del montaggio ed evitare sbalzi di pressione. In caso di pressioni statiche superiori a 5 bar si raccomanda l'installazione di un riduttore di pressione per evitare danni al soffione. Evitare strozzature al flessibile e predisporre una canalina idonea per il passaggio del cavo elettrico.

TECHNICAL WARNINGS

The pipes have to be rinsed thoroughly before installation to avoid pressure differences. In case of static pressure above of 5 bar pressure, it is suggested to install a pressure reducer to avoid and damage to the showerhead. Avoid the hose throttled and prearrange a raceway for the electric cable.

TECHNISCHE WARNUNG

Spülen Sie die Leitungen vor dem Einbau und verhindern Sie Wasserdruckwechsel. Wenn Wasserdruck größer als 5 bar ist, empfiehlt man die Installation eines Druckminderers, um Beschädigung der Kopfbrause zu verhindern. Verhindern Sie Einschnürungen des Schlauches und bereiten Sie einen geeigneten Kanal für Durchlass des Kabels vor.

ADVERTENCIA TÉCNICA

Purgar bien las tuberías antes de la instalación y evitar cambios bruscos de presión. En caso de presiones estáticas superiores a 5BAR se aconseja la instalación de un reductor de presión para evitar daños al rociador. Evitar el estrangulamiento del flexo y predisponer un conducto idoneo para el alojamiento del cable eléctrico.

ADVERTISSEMENTS TECHNIQUES

Rincer les tuyaux avant l'installation. Eviter grandes différences de pression. Dans le cas de pression statique supérieure à 5 bar, on recommande l'installation d'un détendeur de pression afin de ne pas endommager la pomme de douche. Évitez les étranglements au flexible et préparez une conduite appropriée pour contenir le câble électrique.

TEMPERATURA DI ESERCIZIO / WORKING TEMPERATURE

🌡️ max. 70 °C
🌡️ max. 158 °F

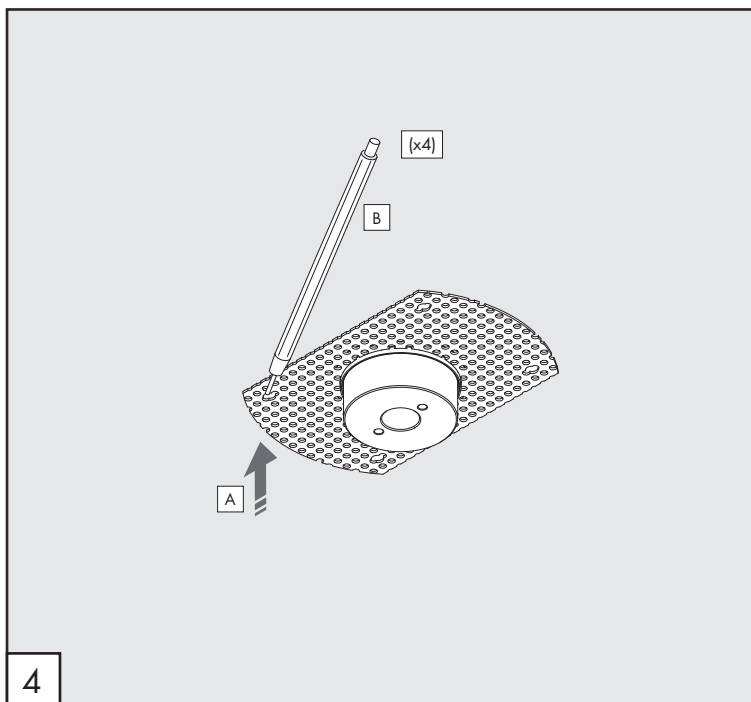
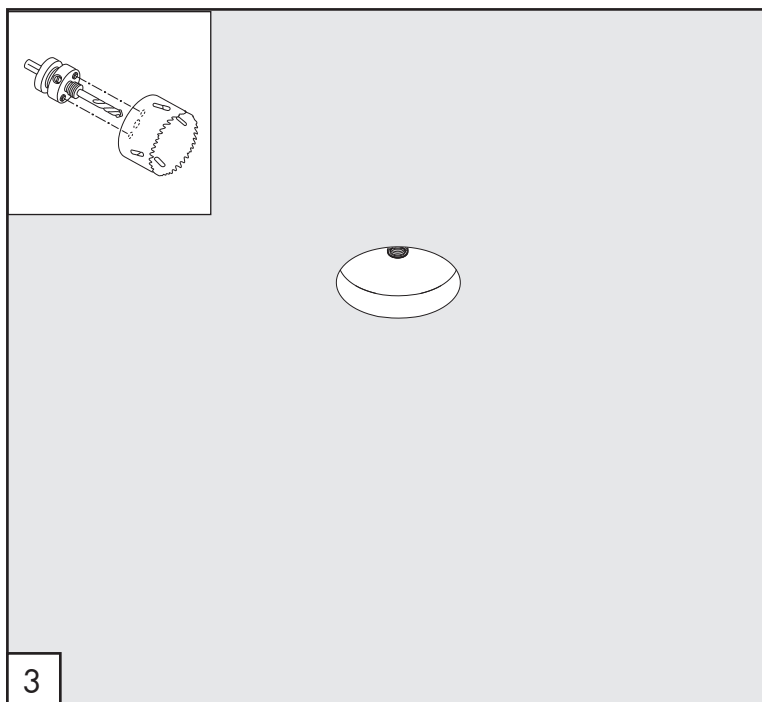

CEA

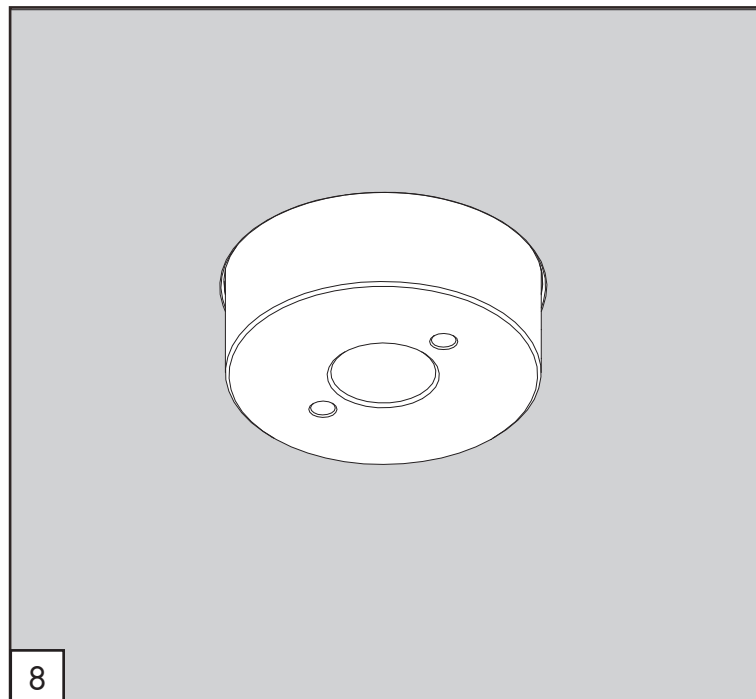
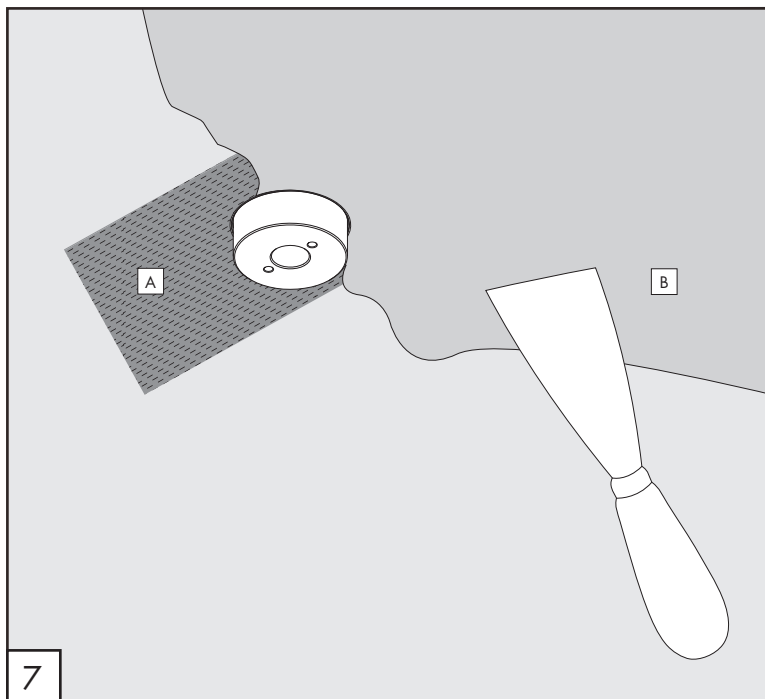
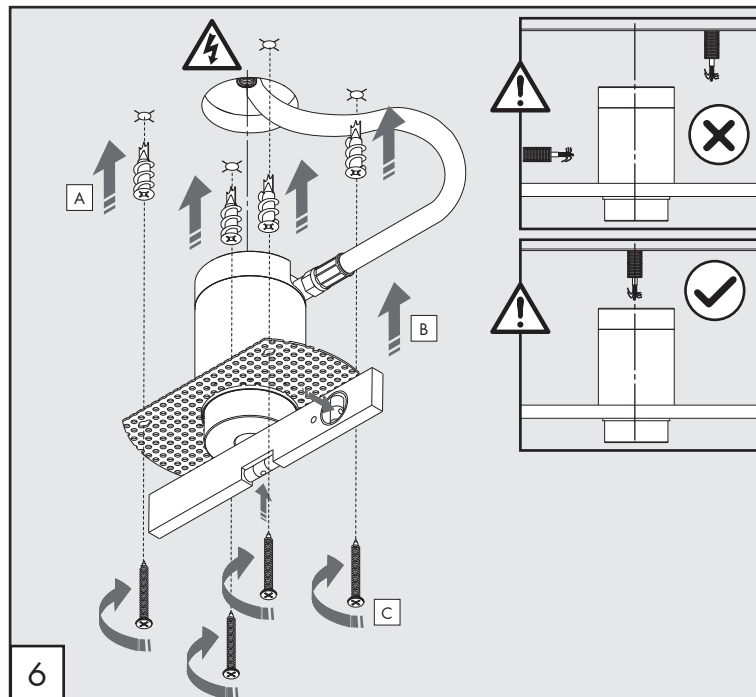
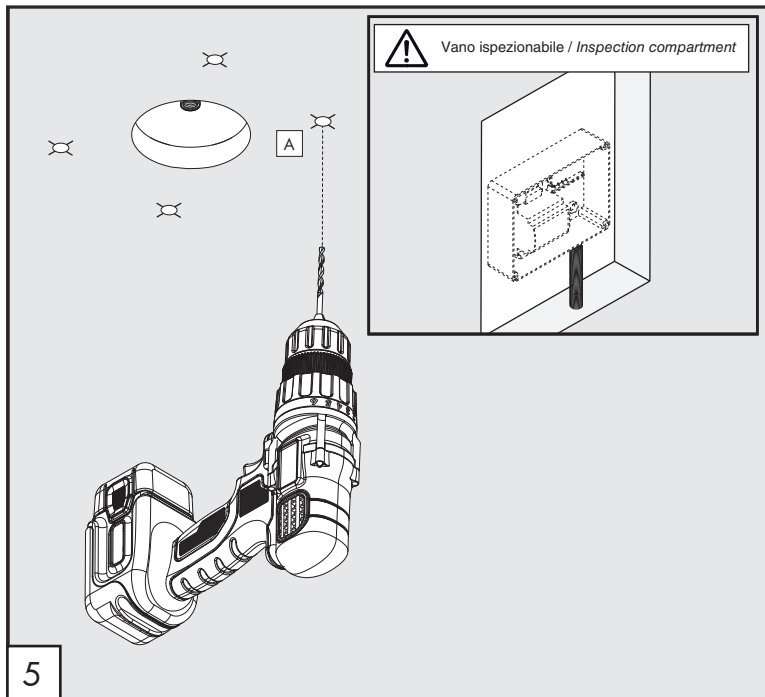

INC18_REV10

CARATTERISTICHE TECNICHE / TECHNICAL FEATURES

Peso prodotto senza acqua Product weight without water *	Kg 0,67
---	------------

* Peso senza parte esterna / Weight without external part

CEQ

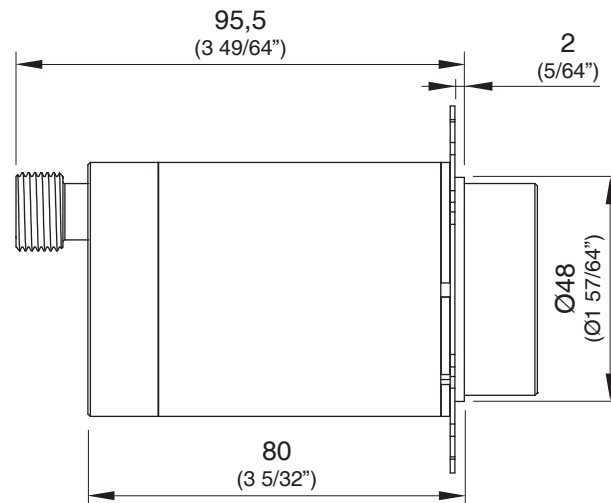
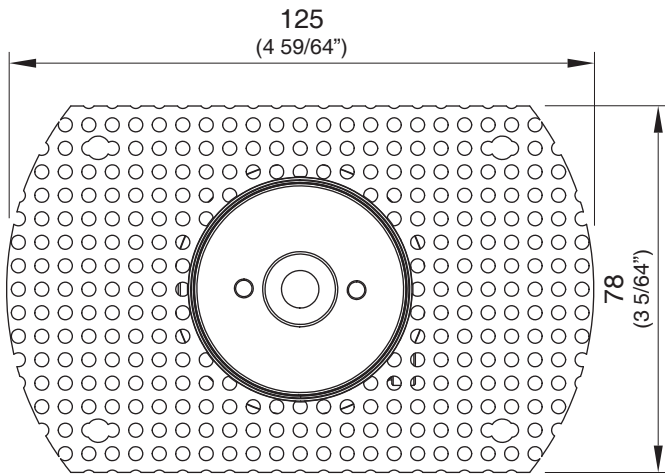

INC18_REV10

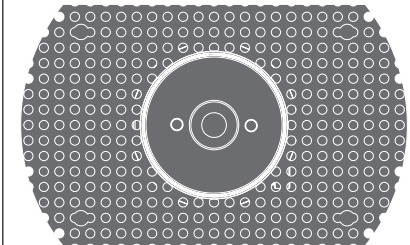

CEADESIGN STUDIO

AISI 304 STAINLESS STEEL

Corpo incasso obbligatorio per soffioni

Mandatory built-in part for shower heads

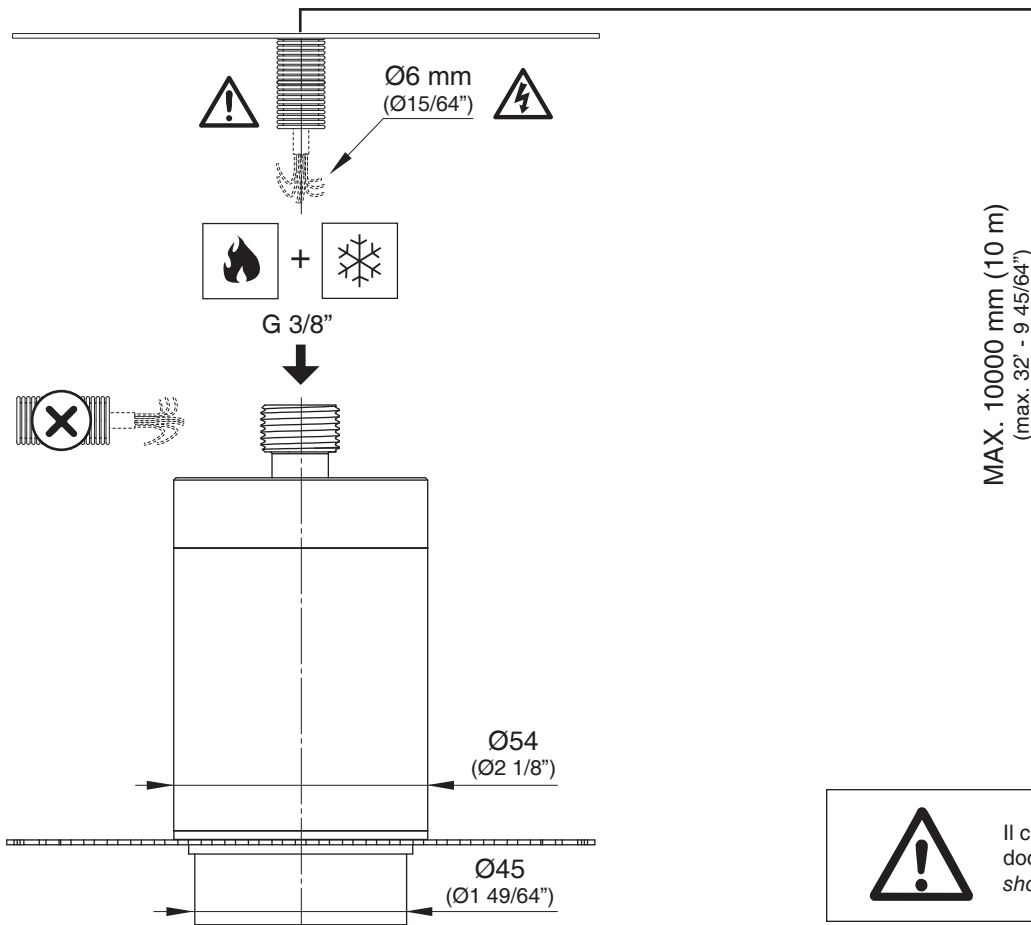

MAX. 10000 mm (10 m)
(max. 32' - 9 45/64")

LED CONTROL UNIT
(ART. CODE ELC01)

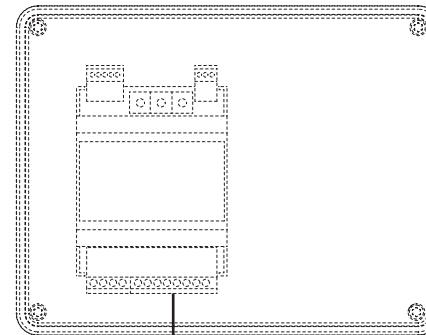

Il cavo elettrico Ø6 mm è compreso con il soffione doccia / The electrical cable Ø6 mm is included with shower head

PRODOTTI CORRELATI / RELATED PRODUCTS

BOT01 - ELC01 - FRE160 - FRE162 - FRE164 - FRE190

Questi disegni sono proprietà di CEADESIGN SRL s.u. pertanto non potranno essere utilizzati e/o comunicati a terzi, anche in forma parziale, senza preventiva autorizzazione. CEADESIGN SRL s.u. si riserva il diritto di apportare modifiche ai disegni al fine di migliorare il prodotto.

CEADESIGN SRL s.u. has the property rights on these drawings, therefore they cannot be used and/or transferred to third party, even in partial form, without any prior authorization. Furthermore CEADESIGN SRL s.u. reserves the right to apply any change to these drawings in order to upgrade the product.

CEA

ceadesign.it

IT

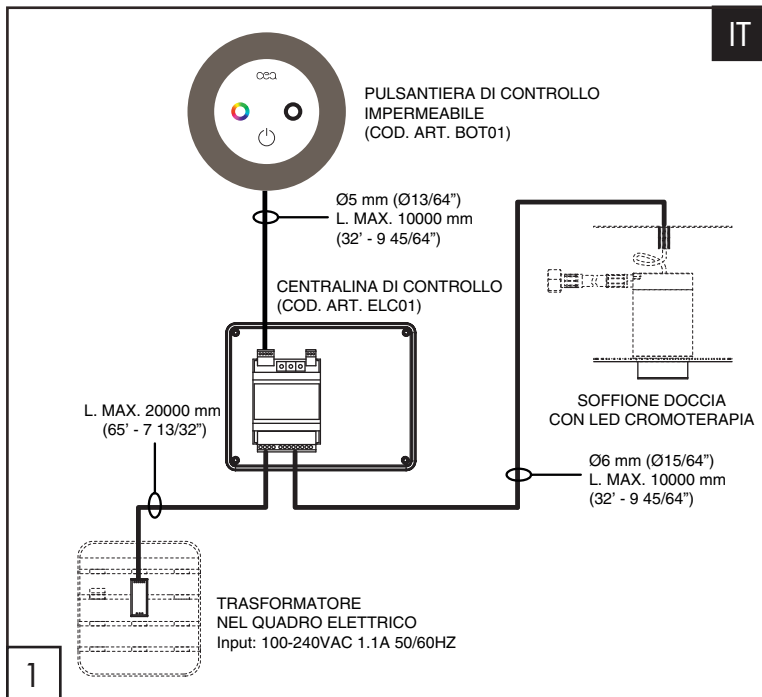

EN

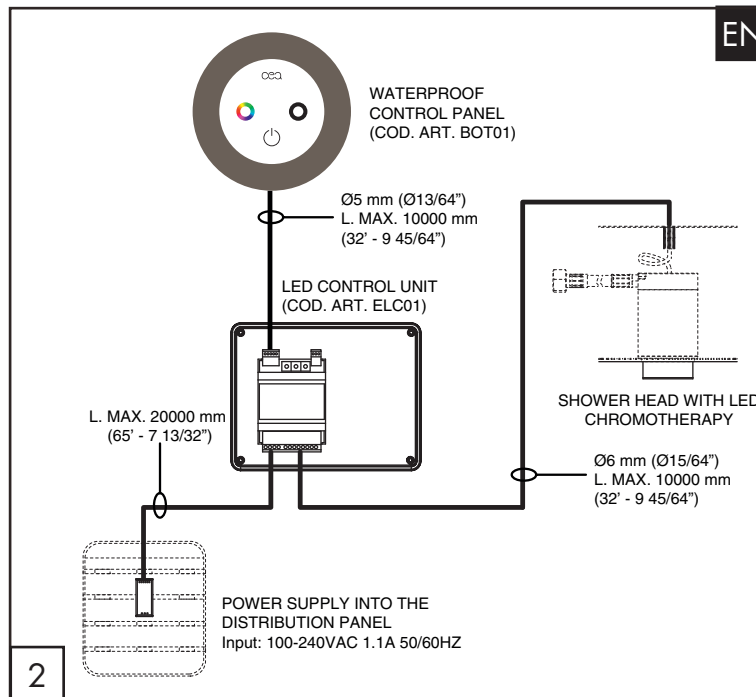

INC18_REV10

AVVERTENZE TECNICHE

Risciacquare bene le tubazioni prima del montaggio ed evitare sbalzi di pressione. In caso di pressioni statiche superiori a 5 bar si raccomanda l'installazione di un riduttore di pressione per evitare danni al soffione. Evitare strozzature al flessibile e predisporre una canalina idonea per il passaggio del cavo elettrico.

TECHNICAL WARNINGS

The pipes have to be rinsed thoroughly before installation to avoid pressure differences. In case of static pressure above of 5 bar pressure, it is suggested to install a pressure reducer to avoid and damage to the showerhead. Avoid the hose throttled and prearrange a raceway for the electric cable.

TECHNISCHE WARNUNG

Spülen Sie die Leitungen vor dem Einbau und verhindern Sie Wasserdruckwechsel. Wenn Wasserdruck größer als 5 bar ist, empfiehlt man die Installation eines Druckminderers, um Beschädigung der Kopfbrause zu verhindern. Verhindern Sie Einschnürungen des Schlauches und bereiten Sie einen geeigneten Kanal für Durchlass des Kabels vor.

ADVERTENCIA TÉCNICA

Purgar bien las tuberías antes de la instalación y evitar cambios bruscos de presión. En caso de presiones estáticas superiores a 5BAR se aconseja la instalación de un reductor de presión para evitar daños al rociador. Evitar el estrangulamiento del flexo y predisponer un conducto idoneo para el alojamiento del cable eléctrico.

ADVERTISSEMENTS TECHNIQUES

Rincer les tuyaux avant l'installation. Eviter grandes différences de pression. Dans le cas de pression statique supérieure à 5 bar, on recommande l'installation d'un détendeur de pression afin de ne pas endommager la pomme de douche. Évitez les étranglements au flexible et préparez une conduite appropriée pour contenir le câble électrique.

TEMPERATURA DI ESERCIZIO / WORKING TEMPERATURE

🌡️ max. 70 °C
🔥 max. 158 °F

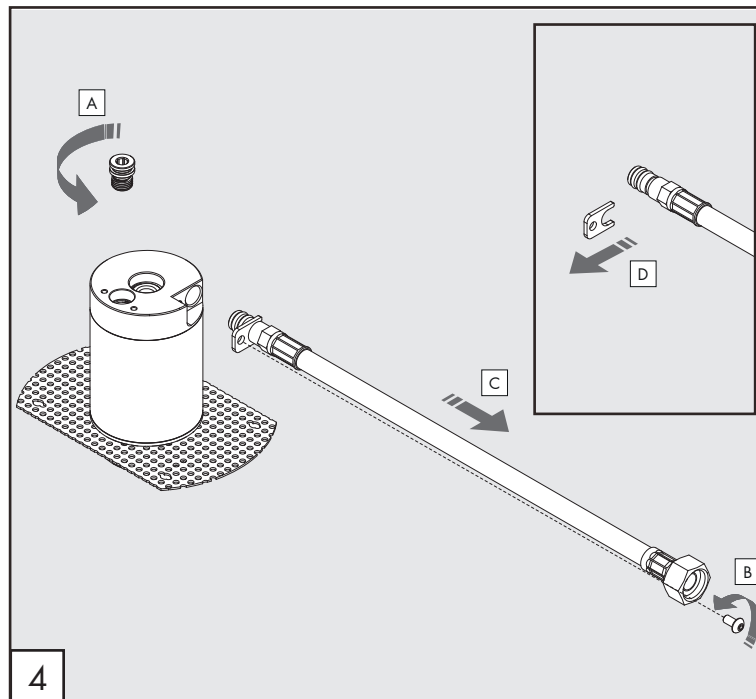
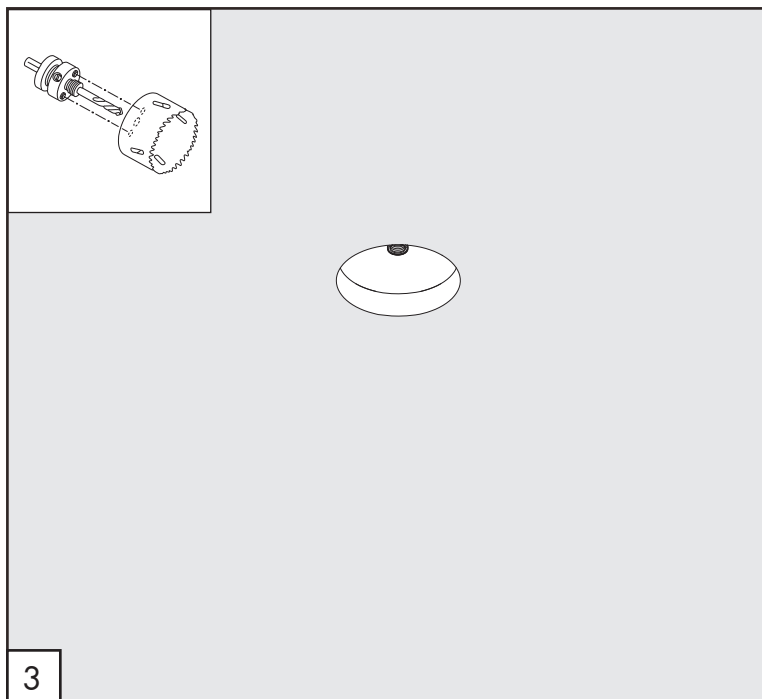

CEA

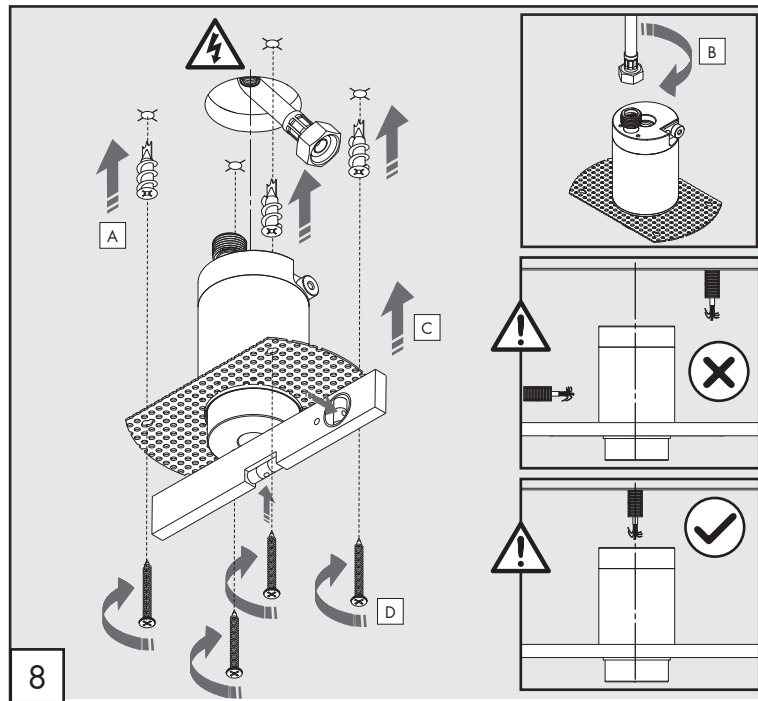
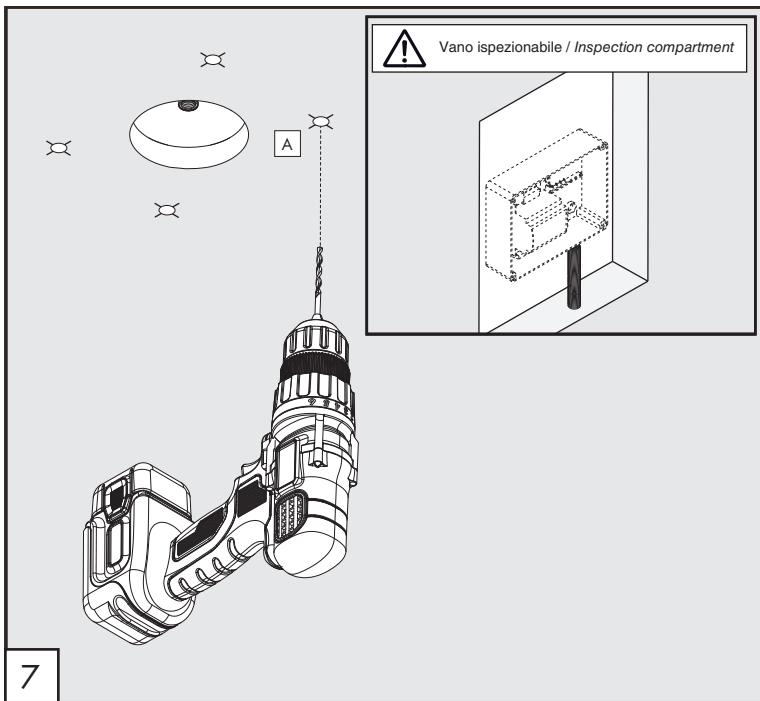
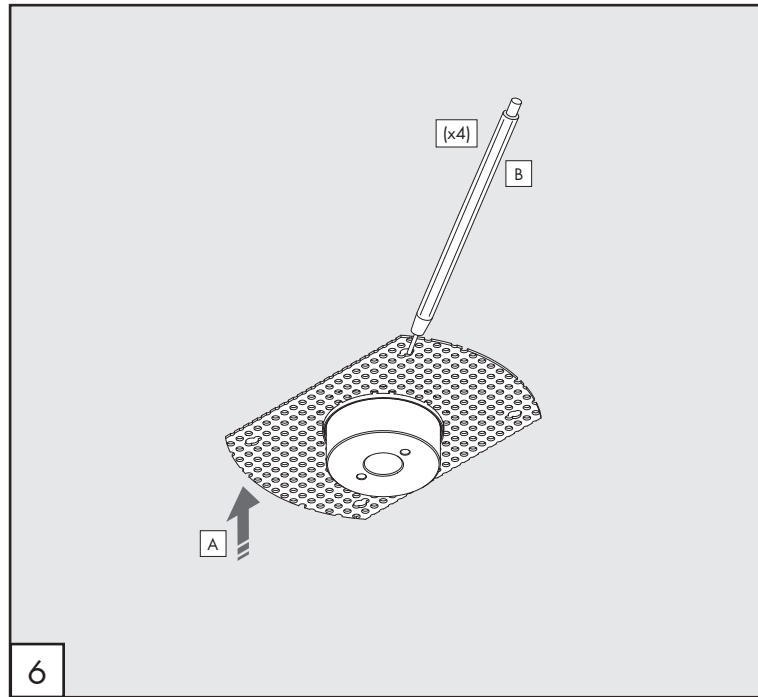
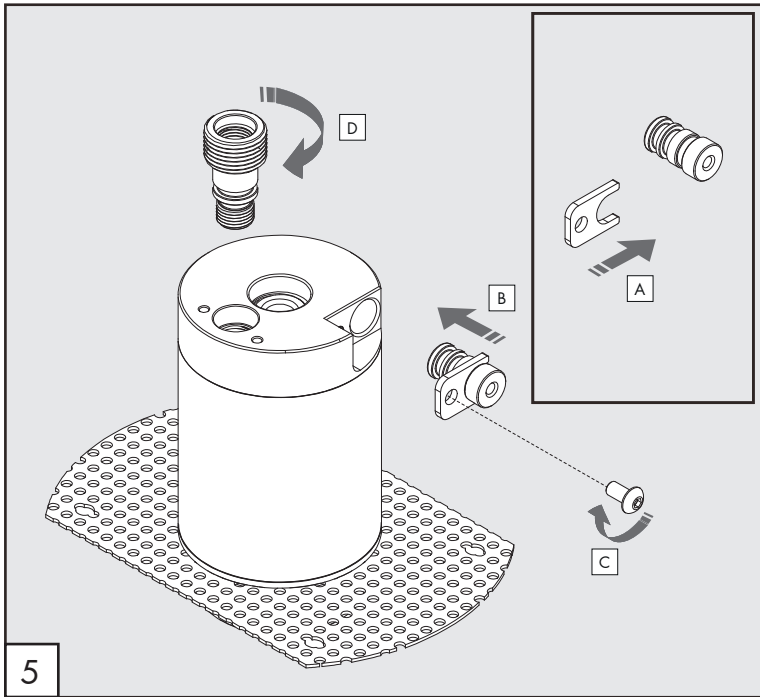

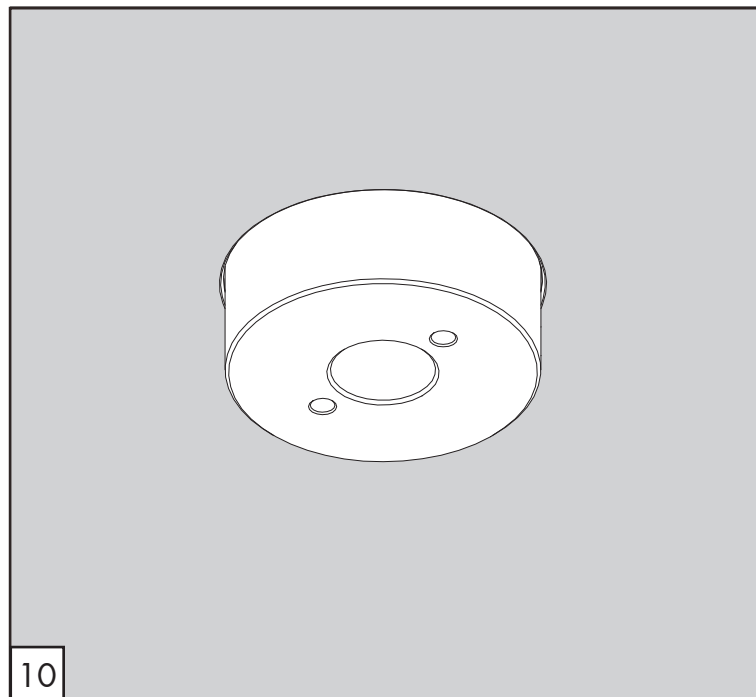
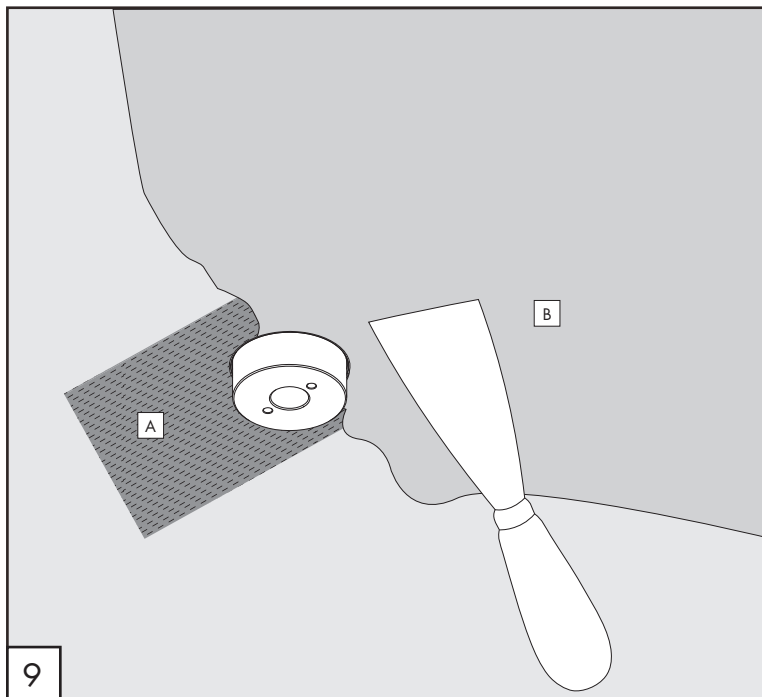

CARATTERISTICHE TECNICHE / TECHNICAL FEATURES

Peso prodotto senza acqua <i>Product weight without water</i> *	Kg
	0,63

* Peso senza parte esterna / *Weight without external part*

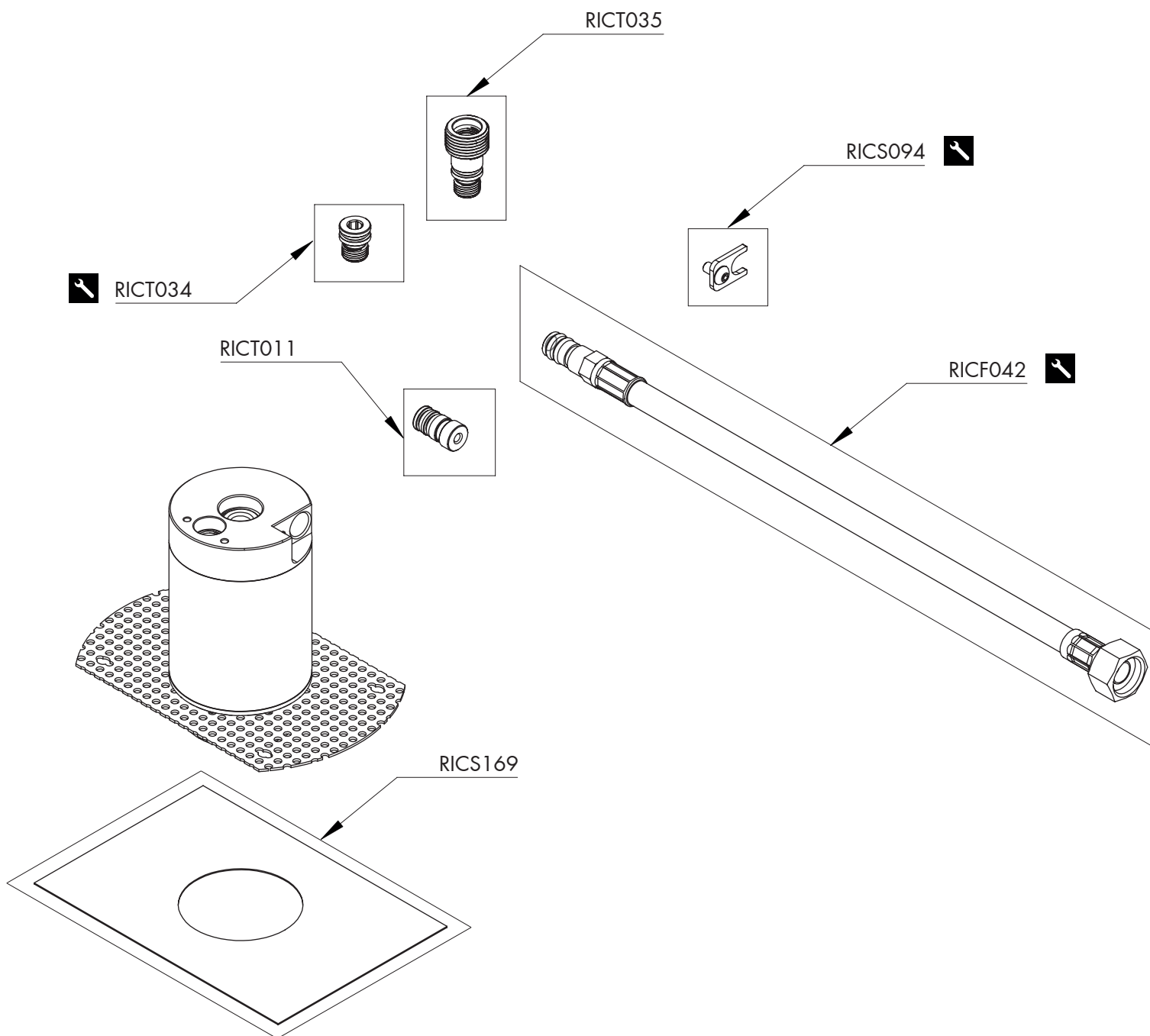

RICAMBI / SPARE PARTS

RICF042	Flessibile / <i>Hose</i>
RICS094	Piastrina di fissaggio / <i>Fixing plate</i>
RICS169	Membrana di isolamento / <i>Insulation membrane</i>
RICT011	Tappo / <i>Plug</i>
RICT034	Tappo / <i>Plug</i>
RICT035	Raccordo / <i>Fitting</i>

LEGENDA / LEGEND

ICONE / ICONS

 Utensile incluso nel ricambio
Tool included in spare part